



SPECIFICATIONS	STANDARD	*SPECIAL
ELECTRICAL		
Center Frequency (Fc)	250 to 5000 MHz	200 to 6000 MHz
3dB Relative Bandwidth (% of Fc)	1 to 10	0.5 to 20
Number of Sections Available	2 to 6	2 to 10
Resonator Size (mm)	3 to 8	1 to 12
Resonator Size (inches)	.12 to .32	.04 to .475
Nominal Impedance	50Ω	50 to 75Ω
Maximum Insertion Loss	See Curve	See Curve
Maximum VSWR	2/1	1.5/1
Attenuation in the Stopband	See Page 22	See Page 22
Maximum Input Power (Average) (Watts to 10,000 ft.)	1	2
Maximum Input Power (Peak) (Watts to 10,000 ft.)	2	10
ENVIRONMENTAL		
Shock	20 G's	75 G's
Vibration	5 G's	30 G's
Humidity	90% relative	100% relative
Altitude	Unlimited	Unlimited
Temperature Range (Operating)	-40 °C to + 85 °C	-55 °C to + 125 °C
Temperature (Non-Operating)	-65 °C to + 125 °C	-65 °C to + 150 °C
MECHANICAL		
Approximate Weight in Grams	L x W x H x 50	L x W x H x 50
Mounting Provisions	See Next Page	See Next Page

*Contact Lark Engineering

INSERTION LOSS:

The maximum Insertion Loss at center frequency is equal to:

$$\frac{LF \times (N + 0.5)}{\% \text{ 3 dB BW}} + 0.2$$

Where:

- LF = Loss Factor
- N = Number of Sections

% 3dB BW:

$$\frac{3\text{dB BW (MHz)} \times 100}{\text{CENTER FREQUENCY (MHz)}}$$

Example:

A 3 section SD with a resonator size of 2mm, a center frequency of 2500 MHz and a 3dB BW of 50 MHz would be:

$$\frac{2.8 \times 3.5}{2} + 0.2 = 5.1 \text{ dB}$$

If loss exceeds 10dB go to a larger resonator or consult Lark.

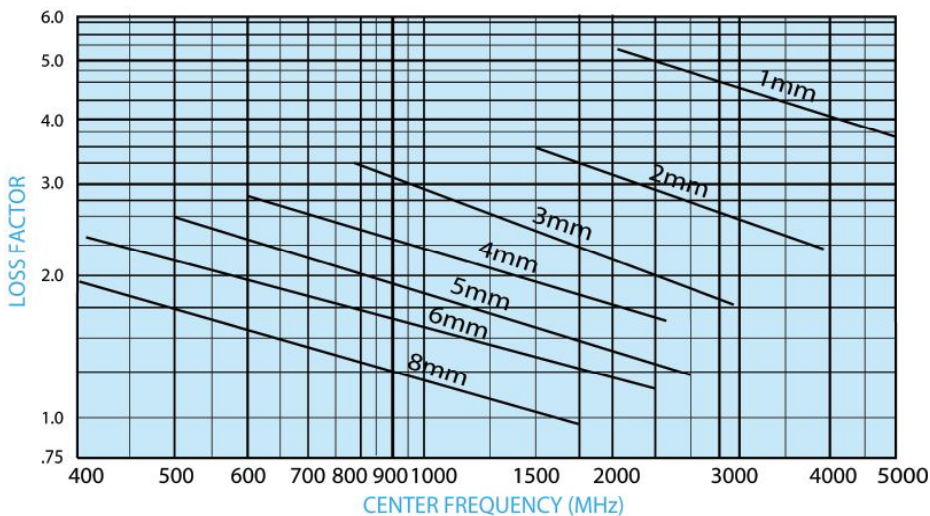

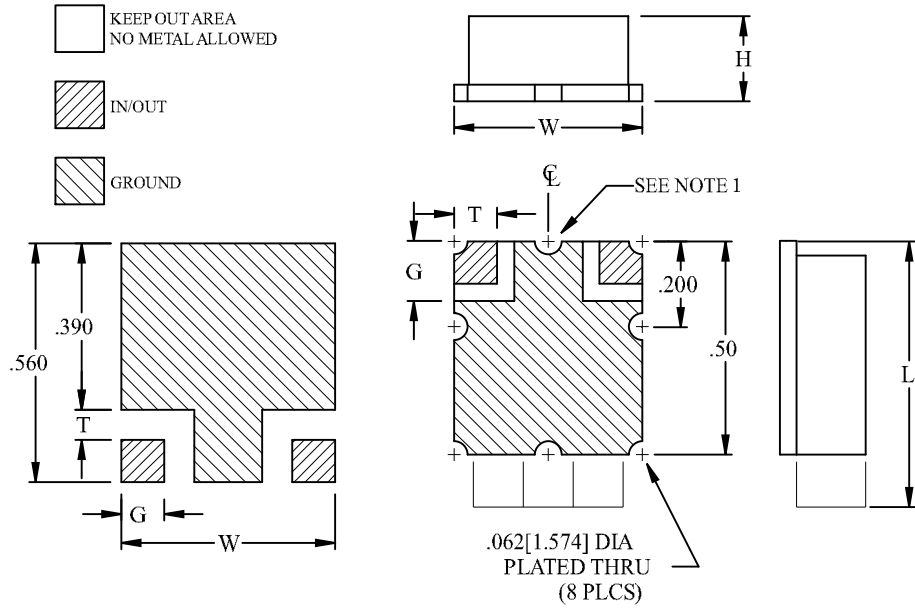

Note 1 - Additional plated thru holes will be provided on this edge, as space allows.
 Note 2 - All dimensions are in inches unless otherwise specified.

For widths (W) less than 0.400 and/or F_c greater than 3000 Mhz, Insulating gap (G) is 0.100 and Pad size (T) is 0.070.

The approximate width (W) of a Lark SD series filter can be determined by the formula:

$$W = N \times RS + 0.09$$

Where N is the number of sections and RS is the resonator size in inches (see below). The minimum possible width (W) is 0.250, the maximum height (H) of a Lark SD series is determined by the chart below.

For widths (W) greater than 0.400, Insulating gap (G) is 0.140 and pad size (T) is 0.100.

The approximate length of a Lark SD filter is a function of the PCB carrier and the resonator size (see below). Standard lengths of Printed Circuit Boards are 0.250, 0.500, and 0.750. Resonators can extend beyond the length of the PCB as much as 0.150 until the next PCB will be used. The length (L) is equal to:

$$L = FAC/F_c + C$$

Where:

FAC = See Below

F_c = Center Frequency (MHz)

SD Series Height	RS (mm)	RS (inches)	H MAX (inches)
	1	0.04	0.12
	2	0.08	0.16
	3	0.12	0.20
	4	0.16	0.24
	5	0.20	0.28
	6	0.24	0.32
	8	0.32	0.40

FREQUENCY RANGE	FAC	C
800-1200	330	0.15*
1201-2000	490	0.15*
2001-5000	660	0.15*
4000-5000**	840	0.15

*If resonators are 3mm or 4mm then $C = 0.30$
 **Only applies to 3mm resonators.

APPLICATION STANDARDS

Part Number	Center Freq. (MHz)	BW (MHz)	BW LL (dBa max.)	VSWR in BW	DELAY MIN/ MAX(ns)	Min Rejection dBc/MHz	Application
3SD836.5-X25-3CC	836.5	25	3.0	2.0	15/26	30 dBc@Fc+/-77.5	Cellular-AMPS
3SD881.5-X25-3CC	881.5	25	3.0	2.0	15/26	30 dBc@Fc+/-77.5	Cellular-AMPS
3SD964.0-X25-3CC	964.0	25	3.0	2.0	15/24	30 dBc@Fc+/-77.5	Cellular-AMPS
3SD902.5-X25-3CC	902.5	25	3.0	2.0	15/24	30 dBc@Fc+/-77.5	Cellular-AMPS
3SD947.5-X25-3CC	947.5	25	3.0	2.0	15/24	30 dBc@Fc+/-77.5	Cellular-AMPS
3SD888.5-X33-3CC	888.5	33	3.2	2.0	13/23	27 dBc@Fc+/-77.5	Cellular-TACS
3SD933.5-X33-3CC	933.5	33	3.2	2.0	13/23	27 dBc@Fc+/-77.5	Cellular-TACS
3SD886.0-X2-3CC	886.0	2	3.0	2.0	18/24	22 dBc@Fc+/-45	Cordless Phone
3SD931.0-X2-3CC	931.0	2	2.7	2.0	19/24	25 dBc@Fc+/-45	Cordless Phone
3SD904.0-X2-3CC	904.0	2	2.7	2.0	19/24	25 dBc@Fc+/-45	Cordless Phone
3SD906.0-X2-3CC	906.0	2	2.7	2.0	19/24	25 dBc@Fc+/-45	Cordless Phone
3SD926.0-X2-3CC	926.0	2	2.7	2.0	19/24	25 dBc@Fc+/-45	Cordless Phone
3SD915.0-X26-3CC	915.0	26	3.0	2.0	15/23	25 dBc@Fc+/-70	ISM
3SD2450-X100-3CC	2450.0	100	1.9	2.0	6/10	30 dBc@Fc+/-300	ISM
3SD1227-X10-3CC	1227.0	10	4.0	2.0	20/26	16 dBc@Fc+/-35	GPS
3SD1575-X10-3CC	1575.0	10	4.2	2.0	20/25	16 dBc@Fc+/-35	GPS
3SD1542-X34-3CC	1542.0	34	3.4	2.0	12/22	25 dBc@Fc+/-85	INMARSAT
3SD1643.5-X34-3CC	1643.5	34	3.4	2.0	12/22	25 dBc@Fc+/-85	INMARSAT
3SD1747.5-X75-3CC	1747.5	75	2.2	2.0	5.5/11	12 dBc@Fc+/-100	DCS
3SD1842.5-X75-3CC	1842.5	75	2.2	2.0	5.5/11	12 dBc@Fc+/-100	DCS
3SD1880-X60-3CC	1880.0	60	1.7	2.0	5/12	30 dBc@Fc+/-200	PCS
3SD1960-X60-3CC	1960.0	60	1.7	2.0	5/12	30 dBc@Fc+/-200	PCS
3SD2442.5-X90-3CC	2442.5	90	1.5	2.0	4.0/8	30 dBc@Fc+/-300	Wireless LAN

MECHANICAL SPECIFICATIONS

FOOTPRINT

PCB SOLDERING PATTERN LAYOUT

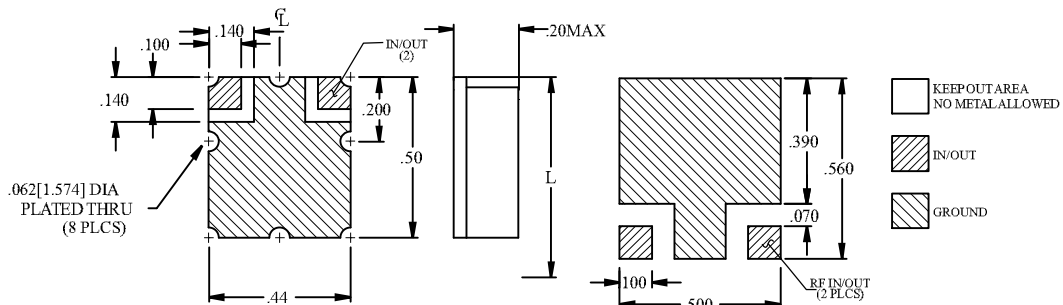

The size shown is a standard used by Lark to facilitate low cost, easily reproduced units. Should you require another size, please submit all of your requirements, both electrical and mechanical, to Lark Engineering. This will enable Lark to quote the optimum design for your application.

APPLICATION STANDARDS

Part Number	Center Freq. (MHz)	BW (MHz)	BW LL (dBa max.)	VSWR in BW	DELAY MIN/ MAX(ns)	Min Rejection dBc/MHz	Application
5SD836.5-X25-5CC	836.5	25	2.7	2.0	28/44	60 dBc@Fc+/-77.5	Cellular-AMPS
5SD881.5-X25-5CC	881.5	25	2.7	2.0	26/39	60 dBc@Fc+/-77.5	Cellular-AMPS
5SD964.0-X25-5CC	964.0	25	2.7	2.0	26/39	60 dBc@Fc+/-77.5	Cellular-AMPS
5SD902.5-X25-5CC	902.5	25	2.7	2.0	26/39	60 dBc@Fc+/-77.5	Cellular-AMPS
5SD947.5-X25-5CC	947.5	25	2.7	2.0	26/39	60 dBc@Fc+/-77.5	Cellular-AMPS
5SD888.5-X33-5CC	888.5	33	3.7	2.0	23/55	60 dBc@Fc+/-77.5	Cellular-TACS
5SD933.5-X33-5CC	933.5	33	3.7	2.0	23/46	60 dBc@Fc+/-77.5	Cellular-TACS
5SD886.0-X2-5CC	886.0	2	3.4	2.0	36/44	50 dBc@Fc+/-45	Cordless Phone
5SD931.0-X2-5CC	931.0	2	3.4	2.0	35/42	50 dBc@Fc+/-45	Cordless Phone
5SD904.0-X2-5CC	904.0	2	3.4	2.0	35/42	50 dBc@Fc+/-45	Cordless Phone
5SD906.0-X2-5CC	906.0	2	3.4	2.0	35/42	50 dBc@Fc+/-45	Cordless Phone
5SD926.0-X2-5CC	926.0	2	3.4	2.0	35/42	50 dBc@Fc+/-45	Cordless Phone
5SD915.0-X26-5CC	915.0	26	2.7	2.0	24/35	45 dBc@Fc+/-70	ISM
5SD2450-X100-5CC	2450.0	100	2.7	2.0	5/21	40 dBc@Fc+/-150	ISM
5SD1227-X10-5CC	1227.0	10	3.2	2.0	27/40	30 dBc@Fc+/-35	GPS
5SD1575-X10-5CC	1575.0	10	3.8	2.0	27/40	30 dBc@Fc+/-35	GPS
5SD1542-X34-5CC	1542.0	34	3.5	2.0	22/36	50 dBc@Fc+/-85	INMARSAT
5SD1643.5-X34-5CC	1643.5	34	3.5	2.0	20/36	50 dBc@Fc+/-85	INMARSAT
5SD1747.5-X75-5CC	1747.5	75	3.2	2.0	10/24	15 dBc@Fc+/-60	DCS
5SD1842.5-X75-5CC	1842.5	75	3.2	2.0	10/24	15 dBc@Fc+/-60	DCS
5SD1880-X60-5CC	1880.0	60	3.5	2.0	15/35	42 dBc@Fc+/-100	PCS
5SD1960-X60-5CC	1960.0	60	3.5	2.0	15/35	42 dBc@Fc+/-100	PCS
5SD2442.5-X90-5CC	2442.5	90	3.2	2.0	10/22	40 dBc@Fc+/-130	Wireless LAN

MECHANICAL SPECIFICATIONS

FOOTPRINT

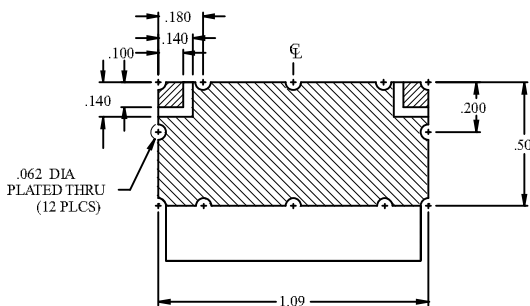

PCB SOLDERING PATTERN LAYOUT

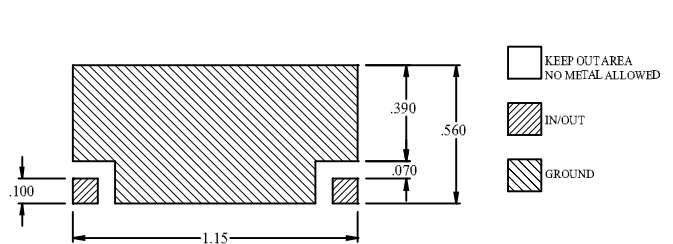

The size shown is a standard used by Lark to facilitate low cost, easily reproduced units. Should you require another size, please submit all of your requirements, both electrical and mechanical, to Lark Engineering. This will enable Lark to quote the optimum design for your application.